



SUMA JEOTEKNİK İNŞAAT TURİZM İRHALAT İHRACAT TİCARET VE SANAYİ LTD.ŞTİ
Hasancıklı Mah. EXPO ALANI Arasta çarşısı 89016 sok. no:20U
Onikişubat/KAHRAMANMARAŞ Tel: +90 344 2255597 info@sumajeoteknik.com

FIELD OPERATION MANUAL Hybrid Swellable Packer & Thermal Expansion Sub

HYBRID SWELLABLE PACKERS



Prepared for Technical Review and Field Operations

SUMA JEOTEKNİK İNŞAAT
TUR.İTH.İHR. TIC. VE SAN. LTD.ŞTİ
İnşaat Dr. Suat SİĞİRCİ (Geoteknik)
Dip. Geoteknik (Registration) No: 2328705C
Aslanbey V.D. 782 072 2957
Hasancıklı Mah. 89016 Sk.No:20AU
Onikişubat/KAHRAMANMARAŞ



Purpose of This Document

This document has been prepared to support the technical review and field operation of the Hybrid Swellable Packer and Thermal Expansion Sub.

The purpose of this manual is to clearly demonstrate the correct assembly sequence, installation method, and operational behavior of the tools under field conditions.

This document is intended to be used by technical review teams, field engineers, and operational personnel.





Scope and Limitations

This manual describes the correct field use of the Hybrid Swellable Packer and Thermal Expansion Sub.

It explains how the tools shall be assembled, run into the well, and used safely to achieve reliable sealing performance.

Manufacturing details, machining drawings, and fabrication instructions are not included in this document.

HYBRID SWELLABLE PACKER



**SWELLABLE
RUBBER**

**SEALING
ELEMENT
EXPANDS ON
CONTACT
WITH FLUID**

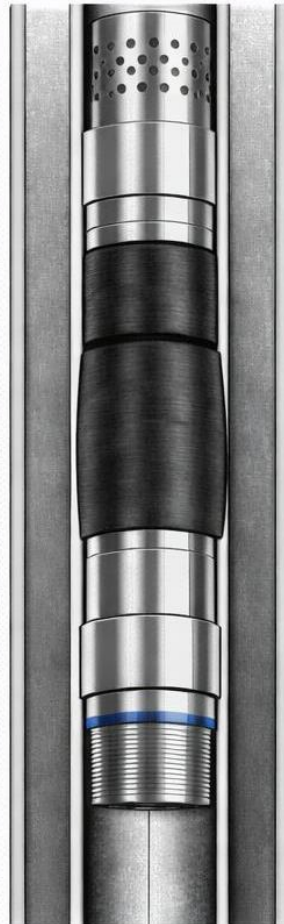

**STEEL
SECTIONS**

**PERFORATED
MANDREL
ENABLES FLUID
CONTACT**

COMBINES STEEL STRENGTH AND SWELLBLE SEALING



Tool Overview

The system consists of a Hybrid Swellable Packer and a Thermal Expansion Sub designed to work together in open hole applications.

The swellable packer provides sealing by radial expansion of the rubber element, while the Thermal Expansion Sub absorbs axial tubing movement caused by temperature changes.





Hybrid Swellable Packer

Only the rubber element of the packer swells when exposed to well fluids. The steel body does not expand and does not provide sealing.

Protective bands are used only for transportation and handling and must be removed before running the tool into the well.

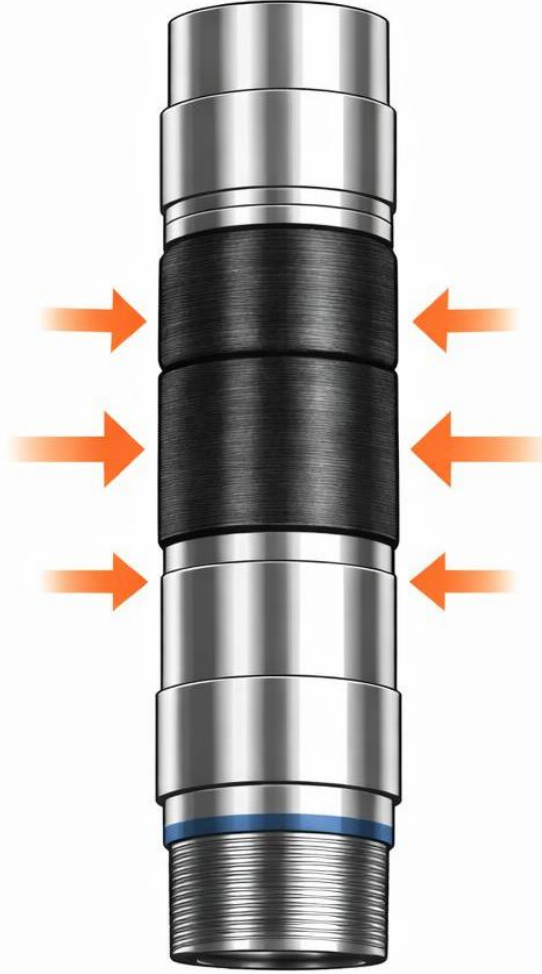

RADIAL EXPANSION

**RUBBER EXPANDS IN DIAMETER
ONLY LENGTH DOES NOT CHANGE**



Thermal Expansion Sub

The Thermal Expansion Sub is installed above the swellable packer to absorb axial tubing movement during well operations.

This tool does not provide sealing and shall always be used in combination with a packer.

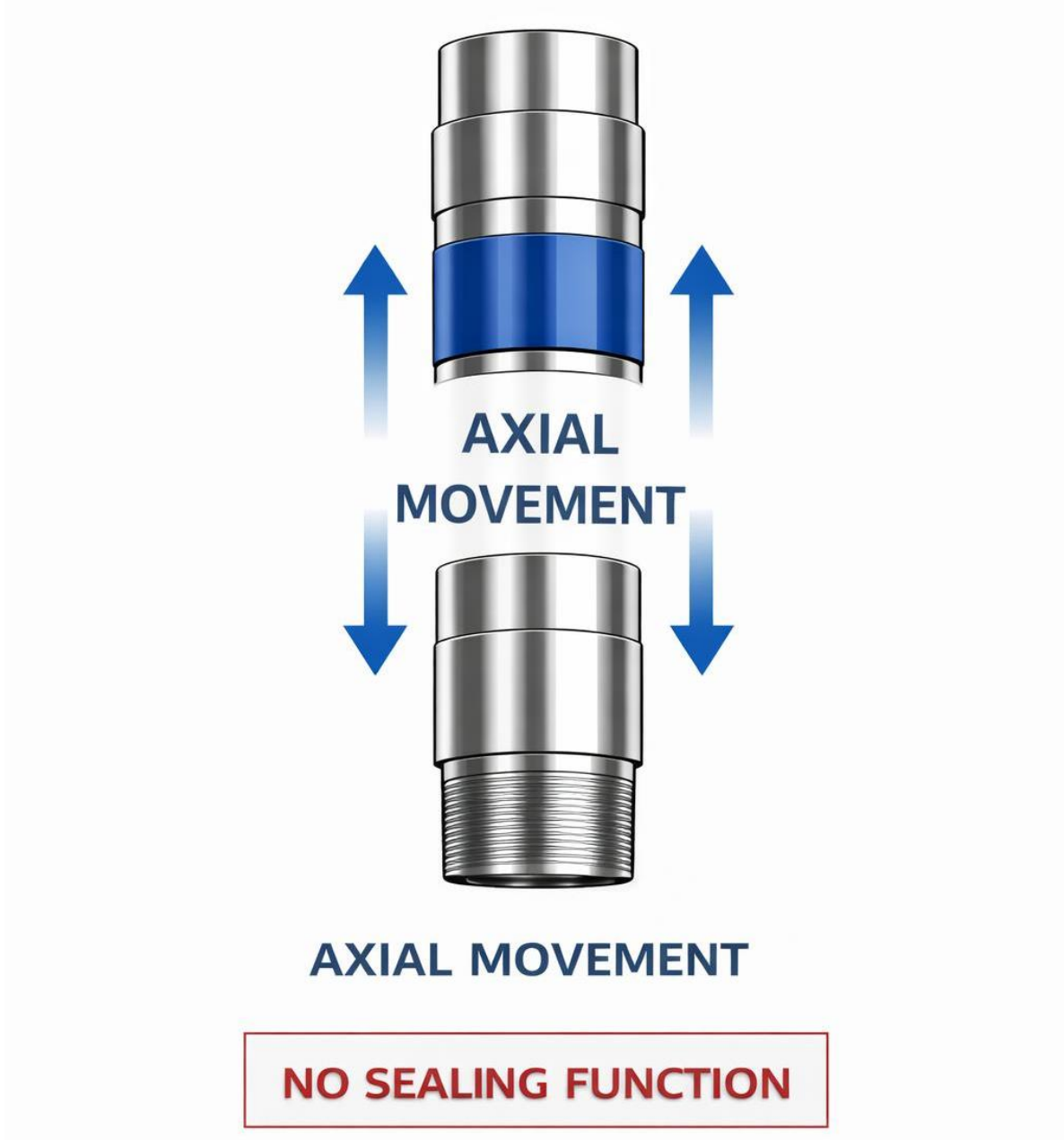



Correct Assembly Configuration

The Thermal Expansion Sub shall always be installed above the Hybrid Swellable Packer.

This configuration ensures that axial tubing movement is absorbed before reaching the packer and prevents excessive axial loading on the swellable rubber element.

CORRECT ASSEMBLY



ALWAYS INSTALL

THERMAL EXPANSION
SUB ABOVE PACKER





Incorrect Configurations

Installing the Thermal Expansion Sub below the packer or omitting it entirely may result in excessive axial loads, rubber damage, and reduced sealing performance.

Such configurations are considered high risk and are not recommended.

INCORRECT ASSEMBLY



**WRONG SUB
BELOW PACKER**



**HIGH RISK
NO THERMAL
EXPANSION SUB**



Run in Hole Procedure

The tools shall be run into the well slowly and in a controlled manner.

Impact loading, shock loads, and dragging against the wellbore wall must be avoided to prevent damage to the swellable rubber.





Post Installation Behavior

After installation, the swellable rubber element requires time to absorb well fluids and expand.

Depending on well conditions, full swelling is typically achieved within 10 to 15 days.

Pressure testing shall only be performed after full swelling has been completed.

POST INSTALLATION



**DAY 1-5:
SWELLING
STARTS**



**DAY 5-10:
SWELLING
CONTINUES**



**DAY 10-15:
FULLY
SWOLLEN**

PRESSURE TEST ONLY AFTER FULL SWELLING

Do / Do Not – Field Summary

DO

- Remove all protective bands before running in hole
- Install Thermal Expansion Sub above the packer
- Run the tools slowly and in a controlled manner
- Allow sufficient time for full swelling

DO NOT

- Do not run the packer with protective bands installed
- Do not install the Thermal Expansion Sub below the packer
- Do not lubricate or coat the swellable rubber
- Do not pressure test before swelling is complete



IMPORTANT LIMIT

MAXIMUM PRESSURE TEST DURATION

1 HOUR

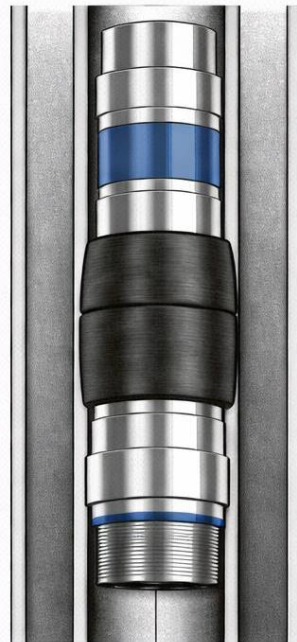

LONGER TESTING MAY PERMANENTLY DAMAGE